

PV Hybrid Inverter for home use

SE300-5048



Features

Safety and reliable



Redundant protection design for full protection
High-quality electric energy output, no interference to home appliances
Protect level IP65 to ensure long time working.
Built-in lightning protection and high-precision leakage current protection, more safe system.

Energy efficient



Soft switching technology, the battery maximum efficiency 94.7%.
Battery standby power as low as 5W.
High-precision MPPT control to ensure maximum PV utilization.
Support 1.1 times long-term overload.

Easy operation



Multi-mode selection, adapt to different scenarios
Friendly LCD interface, easy to operation
Support remote online upgrade, easy maintenance
Highly integrated system, simple and flexible to install

Powerful function



Automatically switch to off-grid when the mains abnormal, less 10ms switching time, the power is never failure.
Strong off-grid output overload capacity meets different loads.
Support RS485, CAN, WIFI multiple communication code.

Internal Frame Structure

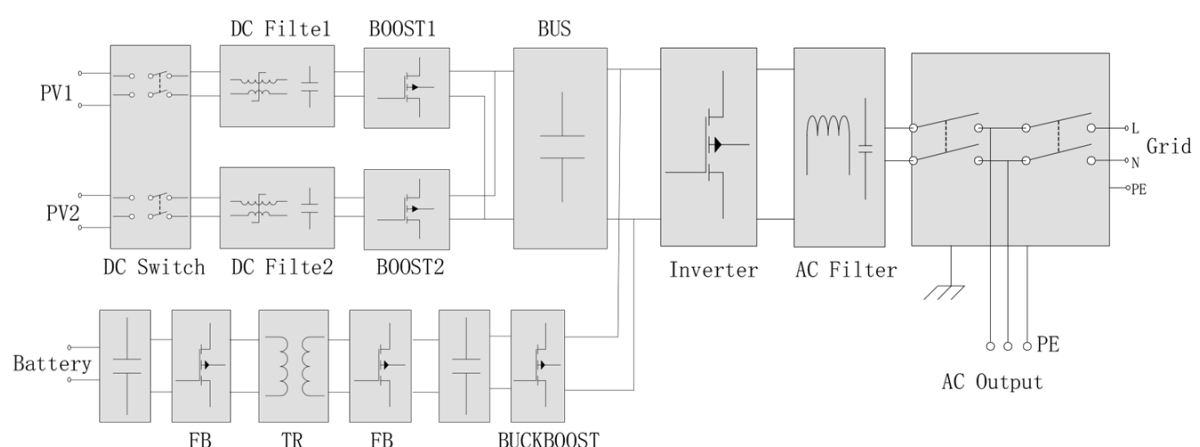

Product Model and Technical Parameters

Parameters	SE300-5048	
PV input	Maximum input power	6000W
	Rated input power	5000W
	Maximum input voltage	580V
	MPPT voltage ranges	125~550
	Start-up voltage	125
	MPPT channels	2
	MPP efficiency	> 99.9%
	DC input channels	2
Battery	Battery types	Lead acid/lithium battery etc.
	Input voltage	51.2V (40-58V)
	Rated charge/discharge power	4600W
	Maximum charge/discharge current	100A
	Voltage, current protection	Yes
	Terminal types	Screw crimping terminal
	Electrical isolation	High frequency isolation
On grid	Rated output power	5000VA
	Rated output voltage/frequency	220V 230V 180V-270Vac 50/60Hz 45-55Hz/55-65Hz
	Rated input/output current	24A
	Power factor	0.99 , (0.8 lead ~ 0.8 lag)
	Grid types	Single
	THDi	< 3%(full load)
Off grid	Rated output voltage	230Vac±2%
	Output frequency	50Hz(60Hz)±0.2%
	Voltage sine wave distortion rate	<3%
	Overload capability	5s@>150%;10s@110%~150%
Efficiency	Maximum efficiency	97.60%
	European efficiency	97.30%
	Standby power consumption	< 5W
	MPPT efficiency	> 99.9%
Certificates and standards	Grid standards	VDE-AR-N 4105 , VDE0126-1-1 , G83/2 , G59/3 , AS4777.2/3
	Safety	IEC62109-1&-2 , IEC62477-1 , IEC62040.1.1, IEC62116
	Electromagnetic Compatibility	EN61000-6-1/2/3/4
Protection	Leakage Protection	Integrated
	Output short circuit protection	Integrated
	DC under-voltage protection	Integrated
	AC under-voltage protection	Integrated
	Valley peak time setting	Integrated
	Island protection	Integrated
	Insulation resistance detection	Integrated
	DC switch	Integrated
Parameters	Size (W * H * D)	595*539*205
	Weight	35kg
	Installation method	Wall mounted
	Ambient temperature	-25~60°C
	Relative humidity	0~95%
	Working elevation	< 3000m
	Noise(dB)	< 25dB
	Cooling	Natural cooling
	Protection level	IP65
	Communication	WIFI,RS485, RS232, CAN
	Display	LCD&APP
	Warranty	5 years